

ERGONOMIC FACTORS INVOLVED IN OPTIMUM COMPUTER WORKSTATION DESIGN

A PRAGMATIC APPROACH

Presented by:

Harry C. Sweere
Chairman, Chief Scientist
Ergotron, Inc., and
Constant Force Technology, LLC
1181 Trapp Road
St. Paul, MN 55121
(651) 681-7600
(651) 681-7710 (Fax)
hsweere@ergotron.com
www.ergotron.com
www.cftproducts.com

Revised 6/14/02



CONSTANT FORCE TECHNOLOGY, LLC

ERGONOMIC FACTORS INVOLVED IN OPTIMUM COMPUTER WORKSTATION DESIGN

A PRAGMATIC APPROACH

Ergonomics: *Application of scientific knowledge to the work place in an effort to improve the well being and efficiency of workers.*

“The future...depends on how we develop human interfaces that create a match between the internal rhythms of the operator and the computer.”

– Dr. Joel Orr, Computer Graphics Consultant –

Background

Over the past several years numerous scientific papers have been written on the ergonomic factors involved in computer workstation design. This paper will not attempt to duplicate the large base of scientific knowledge and the many ergonomic studies already well documented. The goal of this paper is to offer a practical guide to interpreting published ergonomic guidelines and the anthropometric data that can be used to create a user friendly, ergonomically correct computer work environment.

Many factors are involved in the design of a computer workstation such as:

- **VDT adjustability**
- **Keyboard placement/adjustability**
- Worksurface adjustability
- Chair design/adjustability
- Foot rests
- Wrist rests
- Glare screens
- Lighting, task lighting
- Ease of adjustability
- Accessibility to components
- Human Computer Interfaces (HCI's)
- Space savings

All of the above issues concern themselves with the reduction or elimination of a class of physical disorders associated with poor ergonomic design known as Musculoskeletal Stress Disorders (MSD's), which result in:

- Eye, neck and back strain
- Fatigue, headache
- Wrist, hand, elbow and shoulder diseases
 - Carpal Tunnel Syndrome
 - Tenosynovitis
 - Tendonitis
 - Synovitis

Some of the primary causes of eye, neck and back strain, which cause visual problems and wrist, hand, elbow and shoulder diseases are:

- Improper VDT screen height and the inability to adjust the screen height to individual preferences
- Improper VDT viewing distance and the inability to adjust the same

- Improper VDT viewing angle and the difficulty of adjusting the viewing angle especially of larger monitors
- Improper keyboard vertical, fore and aft and tilt positioning.

A user survey conducted several years ago (Grandjean, et al, 1983) indicated that monitor positioning was a prime factor in assuring a computer operator's comfort. The results of that survey are shown below:

<u>Survey Questions</u>	<u>Response</u>	
	<u>Yes</u>	<u>No</u>
Is a height adjustable screen useful?	97%	3%
Should the screen distance be adjustable?	97%	3%
Should the inclination (tilting) of the screen be adjustable?	92%	8%

Although not included above, the desirability of providing keyboard placement and height adjustability has subsequently been documented extensively because of the high incidence of Carpal Tunnel Syndrome and other health issues associated with keying functions.

Because of the key role played by the monitor and keyboard, this paper will focus on the relevant anthropometric data dealing with various classes of operators and the application of a series of scientifically sound ergonomic rules to determine suggested mounting heights for these important components of computer workstations.

The Expanding "Workstation Environment"

History/Background

Recent advances in networking technology have allowed users to bring computers to the point of use in many applications and locations heretofore not considered a computer workstation. Accordingly, the desktop can no longer be considered the only focus for the corporate Ergonomist or the ergonomic workstation designer. Computers on the factory floor, in warehouses and in hospital rooms are some examples of non-office computer workstations that have become quite common over the last several years. Many of these new applications require a different man-machine interface from the traditional seated desk arrangement considered in much of the published literature. New work positions such as standing, and sit-stand have been added, along with a variety of computer component mounting options including wall mount, ceiling mount, floor mount and mobile applications. In most of these applications, component adjustability is even more important than in the office environment. In many cases several people may operate the same equipment on the same or different work shifts as opposed to the desktop environment which may be fairly static once the equipment is set up for a particular operator.

In each case good ergonomic design principles must be applied to give the operator or a range of operators the optimum man-machine interface and the adjustability required to prevent discomfort and prevent workplace injuries. In many cases the specialized video display mounting technology developed for these work environments can be applied to the desktop to provide ergonomic adjustability and space saving benefits for this environment as well.

New Display Technology

The advent of new flat screen VDT technology offers new opportunities to provide improved ergonomics in office and specialty computer workstation environments. The smaller size and lighter weight of these devices has fostered the development of new mounting solutions that can more easily address the age-old problems of screen height adjustability, screen distance and screen tiltability. Now VDT and other manufacturers can provide low-cost, vertically adjustable desk stands and easy monitor tilt capability, to address the average range of operators in either sitting or standing applications. In addition, specialty devices are available to provide reasonable cost solutions to address special ergonomic issues such as providing screen distance adjustability, comfortable viewing for bifocal users, sit-stand applications and providing vertical adjustability for the 5% female – 95% male range of operators (see chart on Page 4).

Ergonomic Ground Rules

The recommended mounting heights, and range of adjustability required to provide comfortable use by a range of operators, shown in this paper are based upon the following ergonomic ground rules gleaned from the available scientific literature and published standards on this subject:

Screen Height

The recommended screen height for VDT monitors (except in special circumstances such as bifocal use) is that the top of the monitor screen should be set at or slightly below (approximately 1"-2") the eye height of the user when the user is sitting or standing in a comfortable, relaxed position. Whenever possible the screen height should be variable to accommodate personal preferences throughout the day.

Screen Tilt

Ideally an upward tilt with the bottom of the screen tilted toward the operator provides optimum viewing because it provides a consistent focal length when scanning from the top of the screen to the bottom. A tilt range of 12° to 20° is ideal depending upon the size of the monitor. **Note:** When upward tilt is used, special care must be taken to minimize screen glare.

Screen Distance from Operator

Normally the monitor screen should be placed as far away as possible from the operator, consistent with the ability to read the information presented on the screen. (The normal focal length for most people exceeds 30" or greater, however, from a practical standpoint a recommended viewing distance from 18" to 28" is mentioned by several ergonomic standards.) A good rule of thumb for most installations is that the monitor screen should be placed at arms length, with the provision to move the monitor back and forth to suit individual needs being the ideal.

Keyboard Height/Positioning

Keyboards should be placed at a height that allows the operator to operate the keyboard with the forearms level and hands sloping slightly downward. A negatively tilting keyboard, allowing the operator to "keep the wrinkles out of the top of the wrists" is ideal. Fore and aft positioning of the keyboard should be consistent with allowing the hands to move easily over the keyboard

with forearms level and elbows at the sides, maintaining a 90° - 110° angle between upper and lower arms.

Screen/Keyboard Height Variance

Anthropometric data for the average range of male to female operators indicates that the top of the monitor screen to centerline of the keyboard placement should range from 20" to 22" with 21" being a good set-up for most applications.

Visual Representation of Anthropometric Height Range

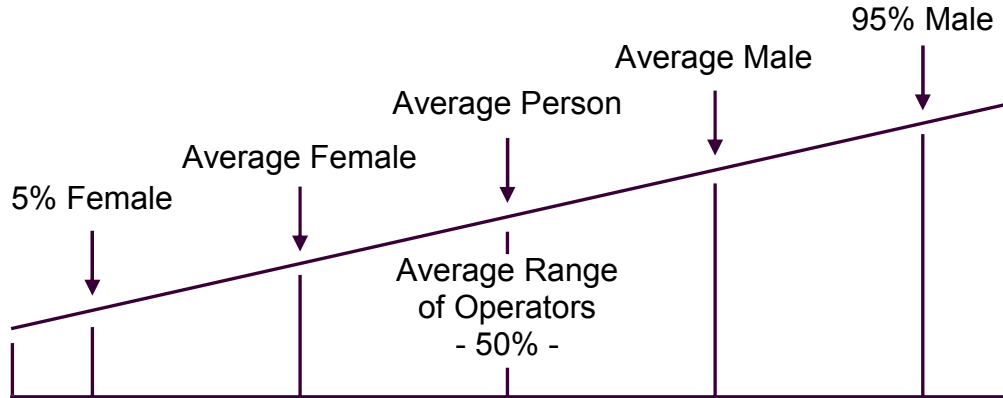

Anthropometric Data: Relating to Screen and Keyboard Height Positioning

Anthropometric Data* (in inches) for Average Range of Operators

	Eye Height			Elbow Height			Eye/Elbow Height Variance	
	Stand	Sit	Variance	Stand	Sit	Variance	Stand	Sit
Av. Female	59.4	44.0	15.4	38.8	23.0	15.8	20.6	21.0
Av. Person	61.7	46.1	15.6	40.4	24.9	15.5	21.3	21.2
Av. Male	64.4	48.5	15.9	42.5	27.0	15.5	21.9	21.5
Variance F/M	5.0	4.5		3.7	4.0			

* Based on an 1988 Anthropometric Survey of US Army Personnel

Ergonomic Design Factors Gleaned from the Above Anthropometric Table

Note 1

- Eye height variance for the average range of male to female operators
- Design criteria used for design of a 6" vertically adjustable VDT mounting apparatus

Note 2

- Elbow height variance for the average range of male to female operators
- Design criteria used for design of most adjustable keyboard mounts

Note 3

- Eye to elbow height variance for the average range of male to female operators
- Optimum top of screen to centerline (C/L) of keyboard relationship for most computer workstations – average 21”

Note 4

- Eye height to eye height variance for the average standing to sitting **person**
- Ideal mounting height for fixed height workstation components that must interface to a range of operators
- Design height adjustment range for a minimum height adjustable screen/ keyboard sit-stand workstation

Note 5

- Eye and elbow height variances for the average standing male to the average sitting female
- Design height adjustment range for a sit-stand workstation designed to accommodate the average range of male and female operators – 20”

Anthropometric Data* (in inches)
for 5% Female and 95% Male Range of Operators

	Eye Height			Elbow Height			Eye/Elbow Height Variance	
	Stand	Sit	Variance	Stand	Sit	Variance	Stand	Sit
5% Female	55.7	40.8	14.9	36.5	20.8	15.7	19.2	20.0
95% Male	68.6	52.1	16.5	45.4	29.5	15.9	23.2	22.6
Variance	12.9	11.3	1	8.9	8.7	2		

* Based on an 1988 Anthropometric Survey of US Army Personnel

Ergonomic Design Factors Gleaned from the Above Anthropometric Table

Note 1

- Eye height variance for the 5% female to 95% male operator
- Ideal eye height adjustment range for a broad range of applications
- Design criteria used for design of 12” or greater vertically adjustable VDT mounting apparatus

4. First line of text on monitor screen – 5° below horizontal line of sight
5. Ideal viewing cone – 5° to 35° below horizontal line of sight
6. Center line of text on screen – 15° to 20° below horizontal line of sight
7. Bottom of monitor screen – dependent upon size of monitor. Screen heights for standard 4 x 3 format monitors are 15" D = 9"; 17" D = 10"; 18" D = 11"; 20" D = 12"
8. Tilt angle of monitor – 12° to 18° dependent upon size of monitor, larger monitors require more tilt to provide equal focal length
9. Worksurface height (29") – shown in relation to bottom of monitor screen for average female operator
10. Worksurface height (29") – shown in relation to bottom of monitor screen for average male operator
11. Anthropometric eye height variance, male to female, sitting application – 4.5"
12. Anthropometric eye height to C/L of keyboard variance – 21"

Note: The average eye heights shown are useful when designing a height adjustable workstation or desk stand for the average range of operators. However, the dimensional relationships can be utilized to design a static workstation for any height operator.

Examples of Ergonomically Adjustable Workstations whose Design is Based on the Above Anthropometric Data

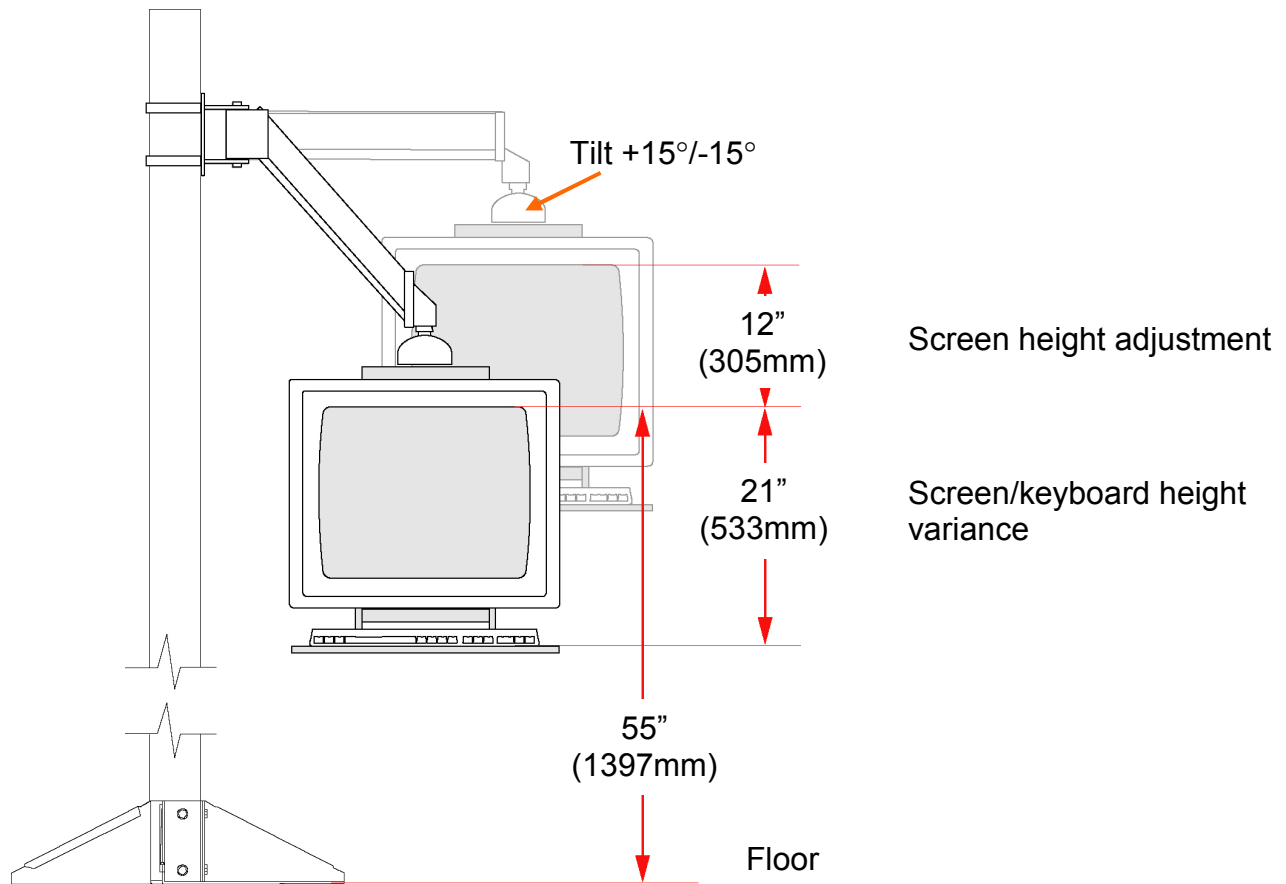

Factory workstation designed to address the 5% female to 95% male population.

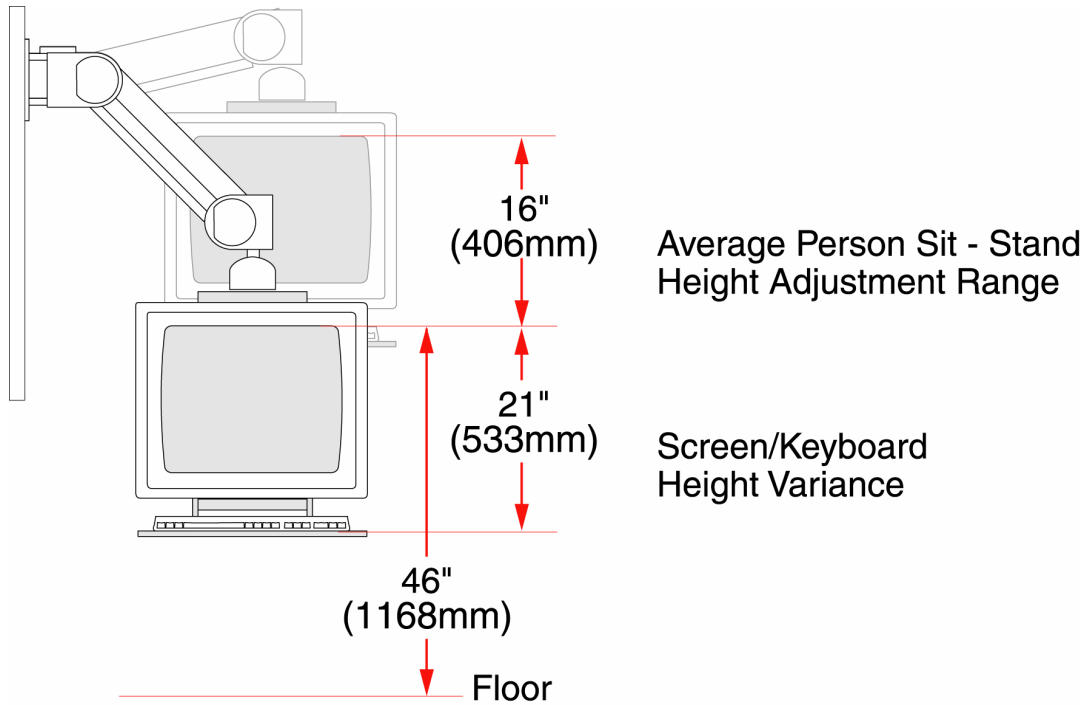

Hospital workstation designed to provide a minimum sit-stand workstation for the average range of personnel.

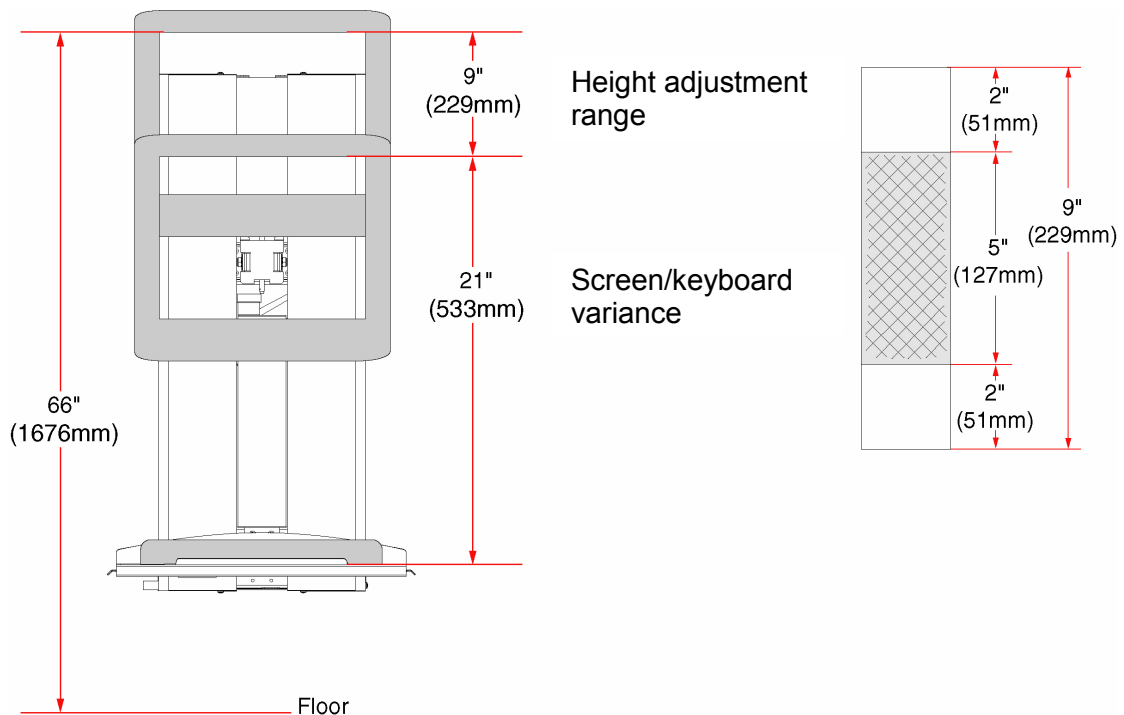

Hospital workstation for standing application, which provides 9" of vertical adjustability and correct screen to keyboard centerline relationship. **Note:** 9" adjustment range is allocated 2" above and 2" below the **average** adjustment range to provide viewing and keying comfort for a broader range of users.

Flat Panel Monitor Technology Offers Potential for Improved Ergonomic Benefits

Flat Panel Arm Office Systems Furniture Automation



Flat Panel Monitor shown at 41" screen height, which is the eye height of the 5% female operator in a sitting position.



Flat Panel Monitor shown at 46" screen height, which is the eye height of the **average** operator in a sitting position.



Flat Panel Monitor shown at 52" screen height, which is the eye height of the 95% male operator in a sitting position.

Flat Panel Arm Office Systems Furniture Automation

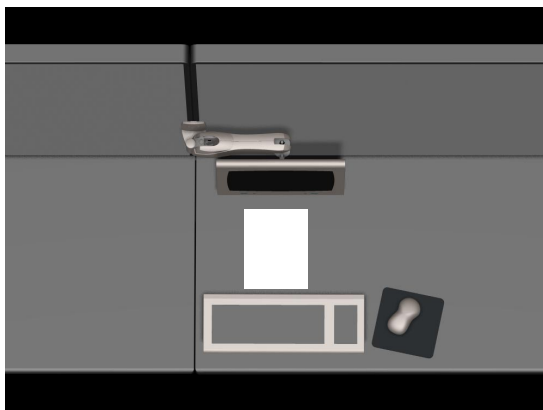

Top view. Flat Panel Monitor installation featuring 5% - 95% vertical adjustability, fore and aft adjustability, monitor tilt and space area for reference materials.

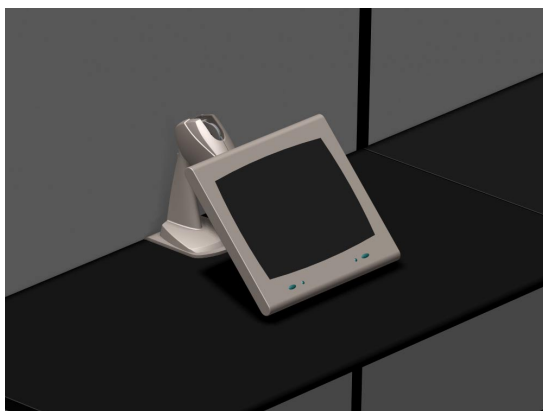

Flat Panel Monitor shown in position optimized for bifocal users.

Low-cost, Full-range Ergonomically Adjustable Desk Stands



Newly developed, low-cost linear counterbalance technology will now allow flat panel monitor and other manufacturers to provide full ergonomic adjustability.

Design of an Ergonomically Correct Desk Stand to meet the average range of male and female users

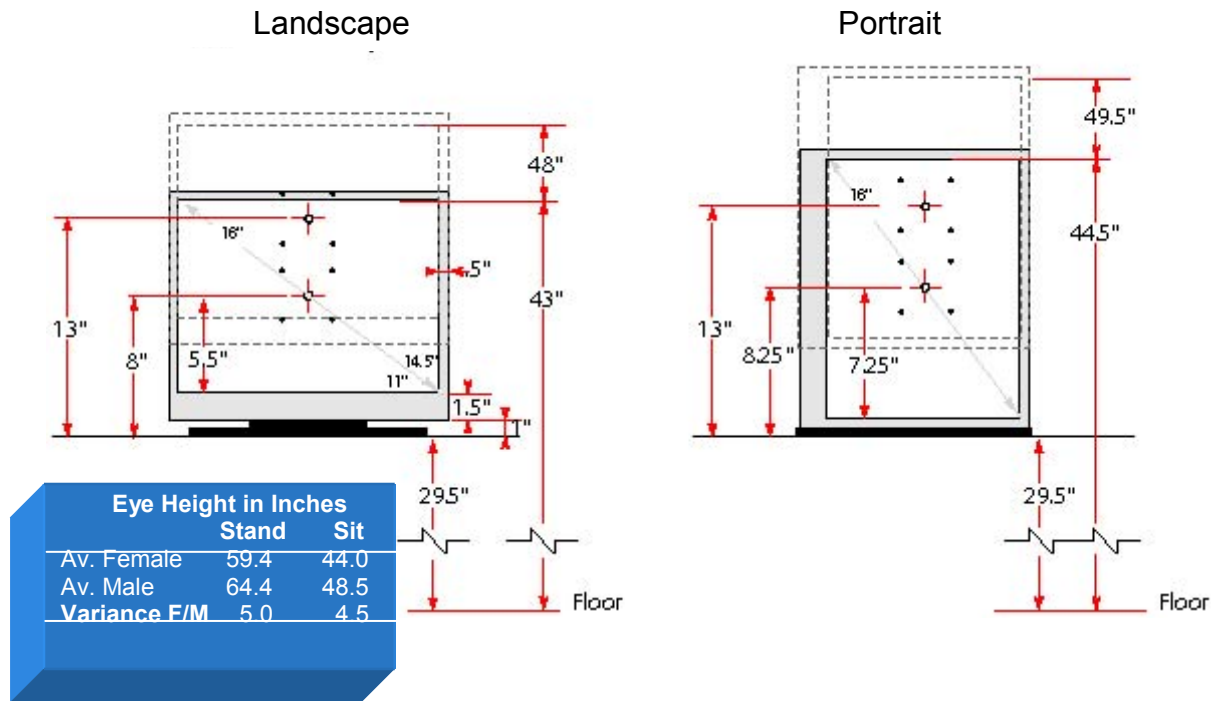

Dual Stacked Flat Panel Monitor Configurations

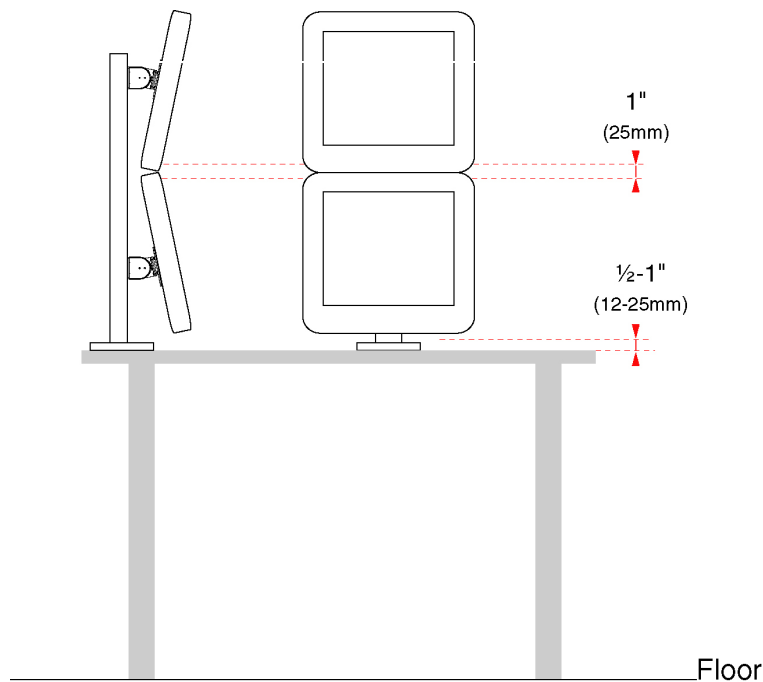

Dual stacked Flat Panel Monitors do not lend themselves to standard ergonomic height rules. In general, the monitors should be set as close to the tabletop as possible, consistent with the ability to create a top to bottom parabolic to improve sight lines. Lower is better than higher because it is more comfortable for the operator to look down than look up for sustained periods.

Conclusion - Summary

Improving the Human Interface with Computers

Ergonomic studies done years ago indicate that screen positioning and keyboard adjustability are some of the most important factors in providing a comfortable work environment and preventing a broad range of MSD's associated with computer use. Disorders such as eye, neck and back strain, fatigue, headaches, and wrist, hand, elbow and shoulder diseases such as Carpal Tunnel Syndrome can all be dramatically improved through use of good ergonomic design.

The foregoing paper is based upon sound ergonomic ground rules and scientific anthropometric data, which can be used by computer workstation designers to help provide an optimum human interface for their computers. However, the science of ergonomics is constantly evolving, therefore all values and recommendations in this paper are provided as **guidelines** only. Workstation designers are urged to consult with a certified Ergonomist who is familiar with the applicable anthropometric data and computer workstation ergonomic standards for corroboration of the recommendations made for each application.

